



**Go Above.
Think Beyond.**

Carrier Toshiba VRF Installation Checklist

**Carrier Enterprise
Technical Services**

Site Name:

Address:

City, State:

Contact:

Zip:

Phone:

NOTE: Please fill one checklist out per system to be started up and commissioned. Check boxes and fill in fields if applicable.

Heat Pump System:

Heat Recovery System:

Qty. of Indoor Units:

Qty. of Flow Selector Boxes:

Total number of VRF systems to be commissioned at time of request:

Centralized control type. If two, list both.

Use separate Centralized Control Checklist for startup request.

Local Controls Used:

Select type and qty.

Prior to startup we recommend you walk the job site referencing the Refrigerant Piping and Control Wiring layout (from V-Pro Software), supplied by Carrier Enterprise. Note any changes on the V-Pro software drawing and return the drawing to the designer for review. This is necessary to verify that any changes will not break the piping rules and/or alter the corrected capacity of the equipment. This is also what we will use to calculate the additional refrigerant charge for the system. After verification, a revised drawing will be provided. It is important to have the additional refrigerant charge calculation before the end of the evacuation process, see Section 9.3. Please plan accordingly.

1. Outdoor Unit – Placement:

Clearances - Enter actual measurements below:

Front Inches Back Inches
 ≥ 40" service & air flow clearance. ≥ 20" service & air flow clearance.

Sides Inches Top Inches
 ≥ 8" service & air flow clearance. > 80" clearance to any obstacle above unit.

Between Unit(s): Inches
 Recommend 8", Can be as little as 0.8".

Wall around unit (If within 3FT of unit) – height Inches

Enter the height difference between the outdoor units: Feet

Header Unit (A):

Follower Unit (B):

Follower Unit (C):

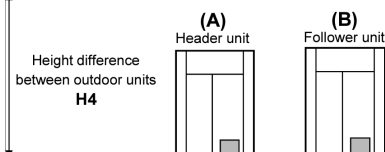
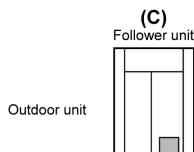
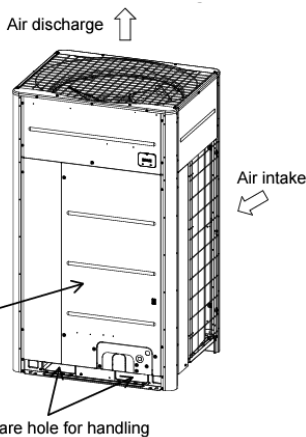

- The Header unit (A) is ≥ the capacity of the Follower unit (B).
- The Follower unit (B) is ≥ the capacity of the Follower unit (C).
- If there is an obstacle above the outdoor unit, leave a space of 78.7" or more to the top end of the outdoor unit.
- If there is a wall around the outdoor unit, make sure that its height does not exceed 31.5".

Header Unit must be the lowest unit, if any elevation difference from Follower unit(s).



**Go Above.
Think Beyond.**

Carrier Toshiba VRF Installation Checklist

**Carrier Enterprise
Technical Services**

Contractor:
Address:
City, State:
Contact:

Zip:
Phone:

2. Outdoor Units – Mounting:

- The outdoor unit is level.
- The mounting base fully supports the unit across front and back.
- All four anchor bolts have been installed and secured.
- There is adequate water drainage for defrost operation.
- The mounting base height is more than the expected snow level.
- Are the refrigerant lines installed underneath the outdoor unit.
- If YES, enter the mounting base height.

Yes
Yes
Yes
Yes
Yes
Yes

No
No
No
No
No
No

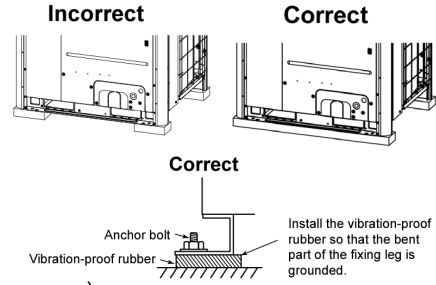

inches (Recommended > 20" clearance)

3. General Refrigerant Piping:

- Line voltage power has NOT been applied to the indoor units.
- When power is applied to the indoor units, the PMV's will begin to drive and could close completely blocking the flow of nitrogen through the system during brazing. See section 15 of this document.
- Confirm there are NOT any added refrigerant components - driers, sight glasses, solenoid valves, etc. None present
- Full port ball valves may be used for component isolation during service.
- Were ball valves installed? Yes No
- If yes, verify all ball valves are in the open position. Yes No
- Nitrogen was purged through the system during all brazing. Yes No
- Enter the pressure setting used to purge nitrogen. PSI
- 15% brazing rods must be used for all brazed joints. Yes No
- During brazing, a wet cloth was wrapped around valves. Yes No
- A R-410A rated flaring tool to form all flare connections. Yes No
- A back up wrench and torque wrench were used on all flare fittings. Yes No

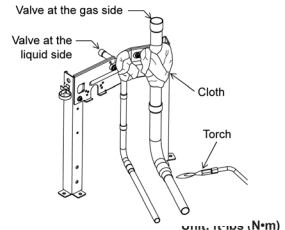

Outer dia. of copper pipe	Tightening torque
Ø1/4 (6.4 mm)	10 to 13 (14 to 18)
Ø3/8 (9.5 mm)	24 to 31 (33 to 42)
Ø1/2 (12.7 mm)	37 to 46 (50 to 62)
Ø5/8 (15.9 mm)	50 to 60 (68 to 82)
Ø3/4 (19.1 mm)	74 to 88 (100 to 120)

4. Combined Outdoor Unit T-Shaped Branching Joint Kits:

Branching Kits for Heat Recovery: RBM-BT14FUL & RBM-BT24FUL
Branching Kits for Heat Pump: RBM-BT14UL & RBM-BT24UL

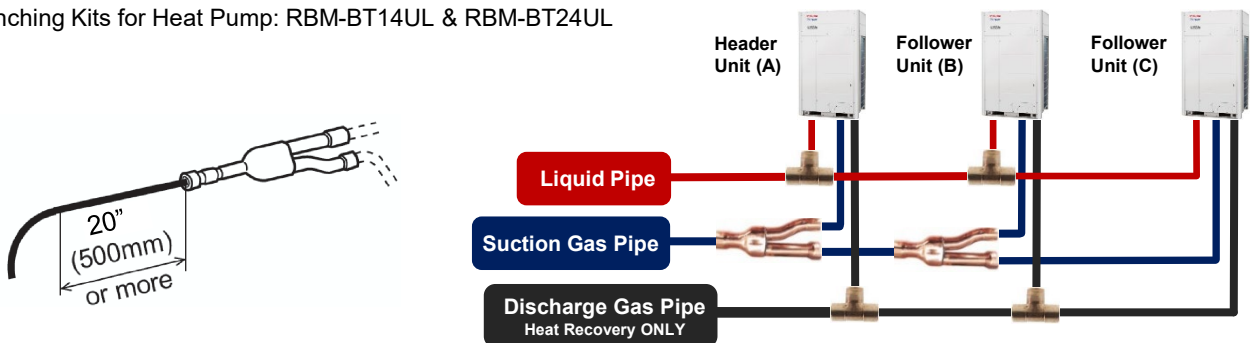



**Go Above.
Think Beyond.**

Carrier Toshiba VRF Installation Checklist

4. Combined Outdoor Unit T-Shaped Branching Joint Kits (cont.):

Branching Kits for Heat Recovery: RBM-BT14FUL & RBM-BT24FUL

Branching Kits for Heat Pump: RBM-BT14UL & RBM-BT24UL

- When attaching a Y-shaped branch unit for the outdoor unit connection piping kit, attach it level with the ground (Be sure not to exceed ± 15 degrees.). Regarding a T-shape branch joints for the liquid side, there is no restriction for its angle.

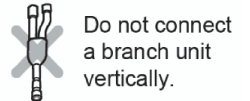
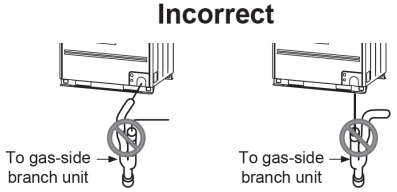
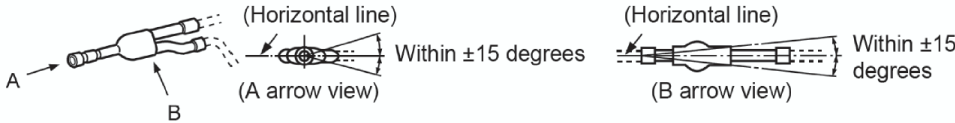

- In case of using the Y-shaped branching joint for connecting between outdoor units (Discharge gas joint and Suction gas joint), please keep the straight part of at least 20" (500mm) at the inlet.

"Crooked" leg of suction gas joint is connected to the header unit.

Suction gas joint is installed horizontal within $\pm 15^\circ$ per instructions.

Liquid joint is installed in the correct configuration per instructions.

Discharge gas joint (If Heat Recovery) is installed in the correct configuration per instructions.

Sockets, joints and insulation were installed per instructions.

Yes	No
Yes	No
Yes	No
Yes	No
Yes	No

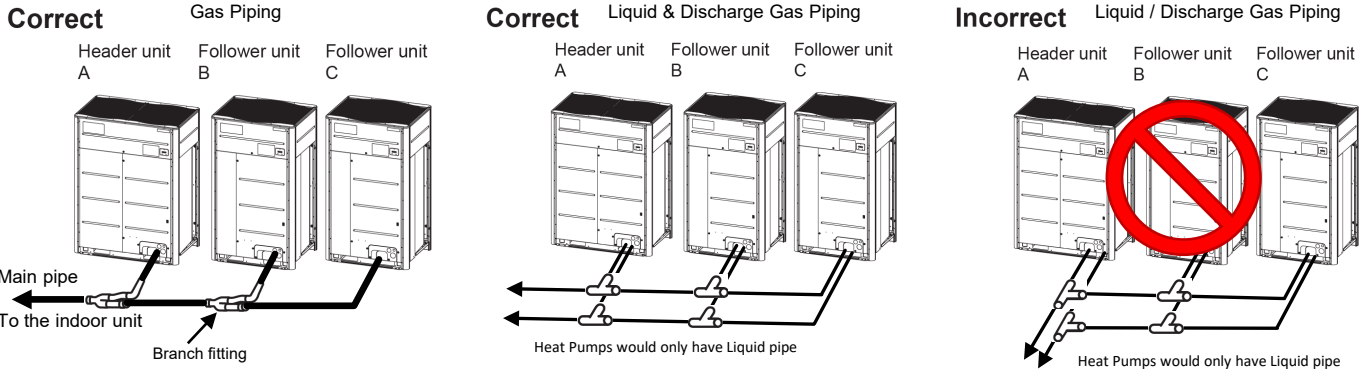

Additional Outdoor Unit piping approved piping configurations can be found in the Install manual of the Outdoor Unit.

5. Outdoor Unit – Refrigerant Piping:

Piping can exit the unit from the **FRONT** or **BOTTOM**.
Bottom recommended on all installs, best for future service access.

If **FRONT**, enter the distance from unit to first turn. Inches ≥ 20 " service clearance

Field installed refrigerant lines are connected per the outdoor unit Install Manual.

Field installed refrigerant lines are within the allowable length & height differences.

Outdoor Unit Install Instructions, H/P pages 12 thru 15, HR pages 13 thru 15.

The field installed refrigerant line sizes and lengths, match the V-Pro Report*

*If at anytime there is a change in the actual piping installation from the design layout, it must be reported back to the designer for verification.

All refrigerant lines are insulated separately with min. $\frac{3}{4}$ " insulation.

Check local code, some municipalities require thicker insulation.

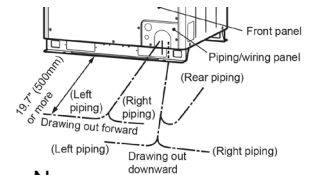

Yes	No
Yes	No
Yes	No
Yes	No



Carrier Toshiba VRF Installation Checklist

NOTE: Be careful not to apply power to Flow Selector Boxes prior to startup. If this happens all equipment must be wired fully and the system placed in Evacuation Mode prior to evacuation, see section 15 of this document.

6.1 Single Flow Selector Units: RBM-Y0611FUPUL & RBM-Y0961FUPUL

Heat Recovery Systems Only – Heat Pumps Systems go to Section 7.

Unit is located in an area where the operating sound will not be objectionable.	Yes	No
Unit is hanging in the horizontal position.	Yes	No
Unit is installed with proper clearances and service access.	Yes	No
The field installed refrigerant line sizes and lengths to the Flow Selector match the V-Pro Report.	Yes	No
If at anytime there is a change in the actual piping installation from the design layout, it must be reported back to the designer for verification.	Yes	No
Nitrogen was purged through the system during all brazing.	Yes	No
A wet cloth was used during brazing to protect the unit's internal components from overheating/damage.	Yes	No
Refrigerant piping and connectors were installed correctly per the unit's Install Manual.	Yes	No

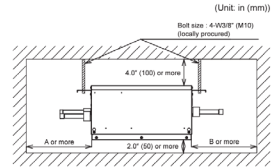

Be sure to wrap the pipe with wet cloth when applying brazing.

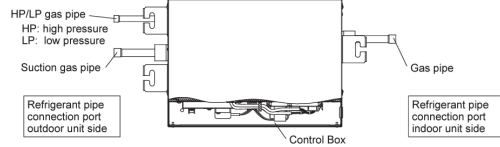
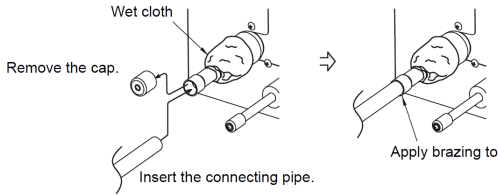

Pipe insulating process

- Insulate the gas and liquid pipes separately as show to avoid capacity loss and sweating.
- The insulation used on the discharge gas pipe must have a minimum temperature rating of 248°F (120°C).
- Use the insulation provided by the accessory to cover all of the joints between the locally procured piping and the FS unit as shown.
- All piping (accessory and locally procured) must be covered with insulation to avoid capacity loss and sweating.

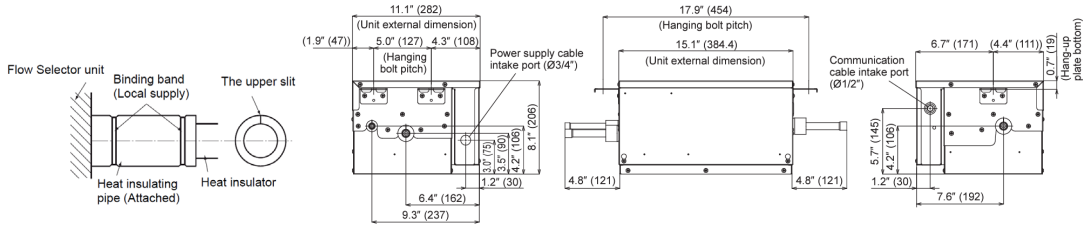

6.2 Multi-Port Flow Selector Units: RBM-Y0611FU4PUL (4-Port) RBM-Y0611FU8PUL (8-Port) & RBM-Y0611FU12PUL (12-Port)

Heat Recovery Systems Only.

Unit is located in an area where the operating sound will not be objectionable.	Yes	No
Unit is hanging in the horizontal position.	Yes	No
Unit is installed with proper clearances and service access.	Yes	No
Enter distance the min and max distances from indoor unit(s). MIN.	Feet.	MAX. Feet.
The field installed refrigerant line sizes and lengths to the Flow Selector match the V-Pro Report*.		
*If at anytime there is a change in the actual piping installation from the design layout, it must be reported back to the designer for verification.		
Nitrogen was purged through the system during all brazing.	Yes	No
A wet cloth was used during brazing to protect the unit's internal components from overheating/damage.	Yes	No
Refrigerant piping and connectors were installed correctly per the unit's Install Manual.	Yes	No
Ports were combined on Multi Flow Selector Box.	Yes	No

Please observe the following:

- Do not combine more than 3 ports.
- Do not make connections between non-adjacent ports.
- Do not combine Port No.4 and No.5
- (in the case of 8 port and 12 port models) and Port No.8 and No.9 (in the case of 12 port model).
- Do not combine Port No.2 and No.3, Port No.6 and No.7, Port No.10 and No.11.

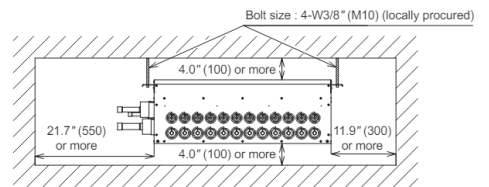
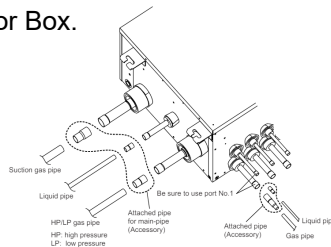



Carrier Toshiba VRF Installation Checklist

6.3 Flow Selector Wiring:

Is the flow selector wired to the same electrical circuit as the indoor units.	Yes	No
Enter circuit breaker size.	AMP	
L1, L2 wiring connected.	Yes	No
Enter line voltage wire size.	AWG	
Ground wire connected.	Yes	No
Communication wire size.	AWG	
Shielded wire used.	Yes	No

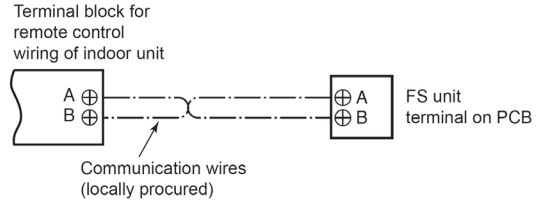

Installer confirmed onsite that refrigerant lines and communication wires match the correct port on Multi Flow Selector Box.	Yes	No
--	-----	----

7. Indoor Unit – Mounting:

All indoor unit locations have been verified by Model/Size, site plans & V-Pro Report.	Yes	No
All indoor units are mounted and secured per their installation instructions.	Yes	No
All indoor units are level.	Yes	No

8.1 Refrigerant Piping – Y Joints:

<Gas / Liquid side>
Install the branching pipes horizontally or vertically to make the flow split evenly.

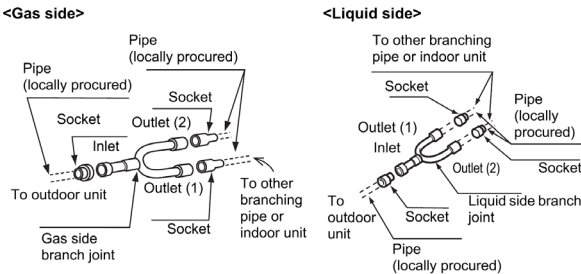

CAUTION

- When a branching pipe is installed horizontally, make its gradient within ± 15 degrees.

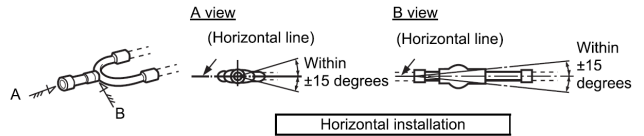

<Gas / Liquid side>
Install the branching pipes horizontally or vertically to make the flow split evenly.

Horizontal within $\pm 15^\circ$ per instructions.	Yes	No	Installed with single end always towards outdoor unit.		Vertical
Are there any "Ys" installed vertically	Yes	No.			
"Y" joints are supported on both ends.	Yes	No			
"Y" joints are the correct size and match the locations as shown on the V-Pro Report.	Yes	No			

8.2 Refrigerant Piping – Header Joints:

Gas side installed horizontal within $\pm 15^\circ$ (indoor unit side).
 Liquid side installed horizontal within $\pm 10^\circ$ (outdoor unit side).
 Header is supported on both ends.

Supporting branching header

After heat insulators are applied to the branching pipes, set some hanging metals (locally procured) as support.

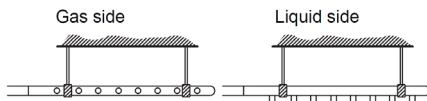

- Install the branching header so that it branches horizontally.

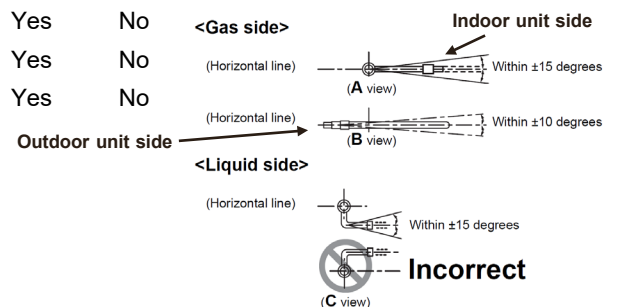

Header joints are the correct size and match the locations as shown on the V-Pro Report.	Yes	No
--	-----	----



**Go Above.
Think Beyond.**

Carrier Toshiba VRF Installation Checklist

8.3 Refrigerant Piping – Min. Distances & Traps:

Sockets, joints and insulation were installed per instructions.	Yes	No
Maintain a minimum distance of 20" between branching joints, headers, elbows and equipment.	Yes	No
Recommend horizontal to be 3 times that of the vertical when traps cannot be avoided.	Yes	No

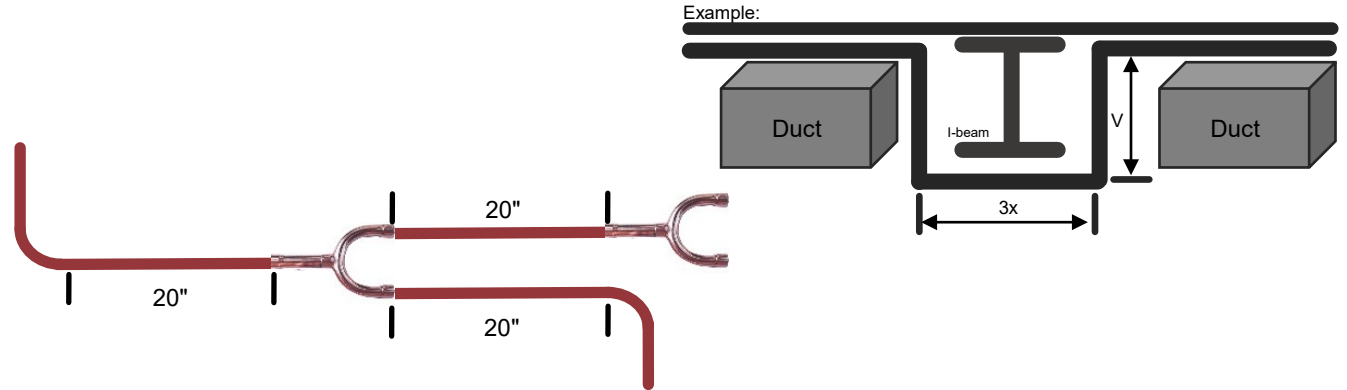

9.1 Refrigerant Piping – Leak Check:

If Heat Recovery System connect to all three main refrigeration stop valves at outdoor unit.	Yes	No
If Heat Pump System connect to the two main refrigeration stop valves at outdoor unit.	Yes	No
Only use Dry Nitrogen.	Yes	No
Enter indoor temp/outdoor temps during 24hr Pressure Test start: Inside	°F	Outside °F
Pressure tested for 24hrs. @ 600PSI.	Yes	No
If not 600PSI enter your final pressure test.		PSI

If the pressure test resulted in a loss of pressure, locate and repair the leak(s). Then re-test as above while taken in to account the following. Compare temperature differences above - there could be an approximate 0.26 PSI difference for every 1°F of temperature change. i.e. - If there was a 10°F temperature rise from start to end, the pressure would have increased approx. 2.6 PSI. Likewise, if there was a 10°F temperature fall the pressure would have decreased by approx. -2.6 PSI.

9.2 Refrigerant Piping – Evacuation:

Note: Do NOT open service valves until a vacuum of 500 microns or below has been achieved and the additional charge has been added. See Section 9.3 for additional charge instructions.

If Heat Recovery System connect to all three main refrigeration stop valves at outdoor unit.	Yes	No
A micron gauge was used.	Yes	No
Verify that the micron gauge is connected at a point where it can read the system's pressure at all times during this process, even when the vacuum pump is not running during the hold test.		
All refrigeration piping has held below 500 microns for 1 hour. Enter final reading.	Yes	No
Enter Triple Evacuation readings and times below.		
Step 1	Microns	Day/Time
Step 2	Microns	Day/Time
Step 3	Microns	Day/Time
Vacuum was broken with additional refrigerant charge.	Yes	No
If not, please explain.		



Carrier Toshiba VRF Installation Checklist

9.3 Refrigerant Piping – Additional Refrigerant Charge:

Do NOT open unit service valves until additional refrigerant charge has been calculated, added and recorded. The V-Pro software calculates the additional refrigerant charge based on the refrigerant piping layout. If at anytime there is a change in the actual piping installation from the design layout, it must be reported back to the designer for verification.

Has the updated copy of Refrigerant Piping & Wiring Layout been sent into CE. Yes No
If not send your revised version to your sales representative for updating.

Enter additional refrigerant charge amount - R410A. Lbs. Oz.

Above is the preferred method of determining the additional refrigerant charge. Refer to the outdoor unit installation instructions for an alternate method. If the alternate method is used, please use the notes page of this document to show how the above amount was calculated. With the system at 500 microns or less the majority (or all) of the additional refrigerant charge can be added at this time breaking the vacuum.

Digital refrigerant scale used to weight in the additional charge on the liquid side of the system. Yes No

Was the total additional charge added at this time. Yes No

If NO, enter the amount of charge added at this time. Lbs. Oz.
The remainder of the additional charge can be added during the system start up process

Record additional charge amount inside the outdoor unit using a permanent marker. Yes No

Open the unit service valves - Suction, Discharge and Liquid. Yes No

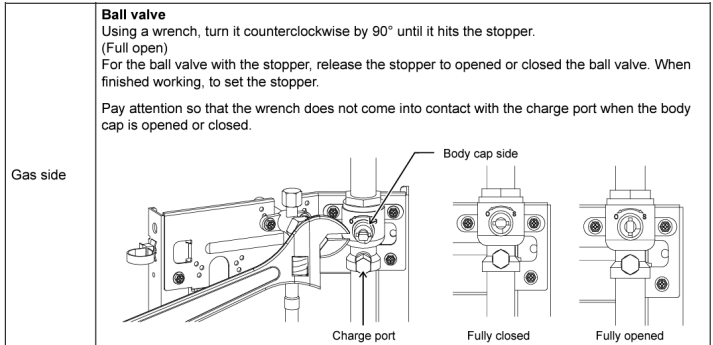
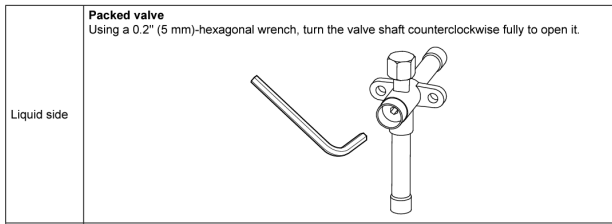

10. Refrigerant Piping – Insulation:

All refrigerant lines are insulated individually. Yes No

Pipe insulation has temperature rating > 248°F and ≥ 3/4" wall thickness. Yes No

Check local codes where job site is located, some areas by code require 1.5" thickness or greater.

Indoor unit line connections are insulated individually. Yes No

Heat insulators supplied with branching "Y" & Header joints are installed per their instructions. Yes No

Heat insulators supplied with indoor units are installed per their instructions. Yes No

There are no gaps between heat insulators and pipe insulation. Yes No

<Gas, liquid side>

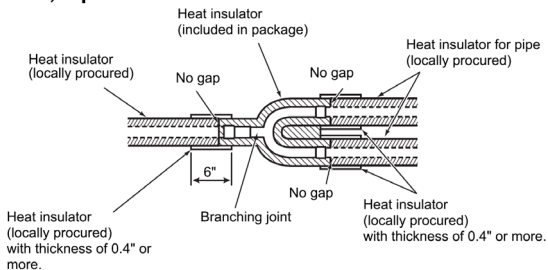

<Gas, liquid side>

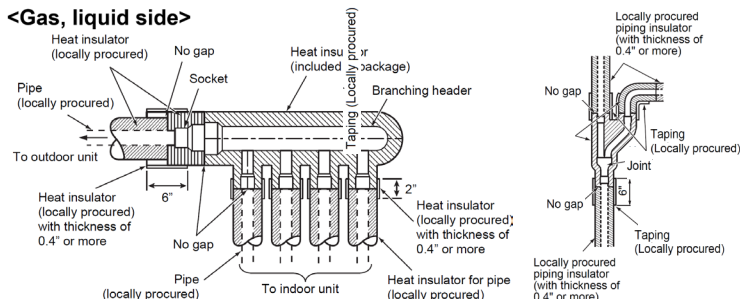



**Go Above.
Think Beyond.**

Carrier Toshiba VRF Installation Checklist

11. Indoor Unit – Condensate Drain Lines:

The following units either have an internal trap or the drain is located on the positive side of the blower.
High Wall; Compact 4 Way Cassette; 4 Way Cassette; Underceiling; Low, Med & High Duct;
Outside Air and Floor Console Units - Do Not require an external condensate trap.

Verify there are no external traps on the above indoor units.

Yes No

Condensate lift pump accessories are available for most indoor units.
Were any accessory pumps required for this application.

Yes No

If YES, verify these accessories have been installed per their instructions.

Yes No

Are there condensate pump safety switch(s) wired to the indoor unit.

Yes No

Cassette's; Low Medium High (2 to 4.5-ton) units have a built-in condensate lift pump.
Verify the drain line is install within the limitations shown in the installation instructions.

Yes No

3x3 Cassette

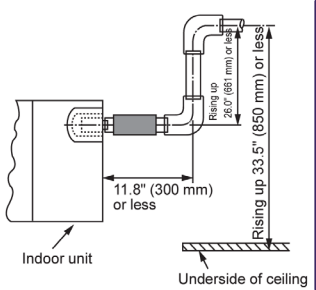

2x2 Cassette

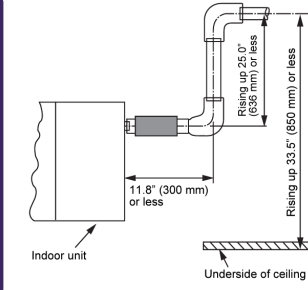

Low Ducted

For drain pipes that will be connected after setup, make a downward slope of 1/100 or more.

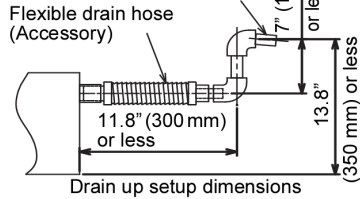

Med. & High Ducted (2 to 4.5-ton) & Outside Air unit 481

For drain pipes that will be connected after setup, make a downward slope of 1/100 or more.

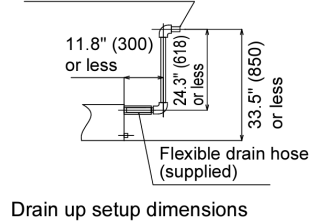

Vertical Ducted Fan Coil units - require an external trap
The drain is located on the negative side of the blower.
Verify the traps are formed per the unit installation instructions.

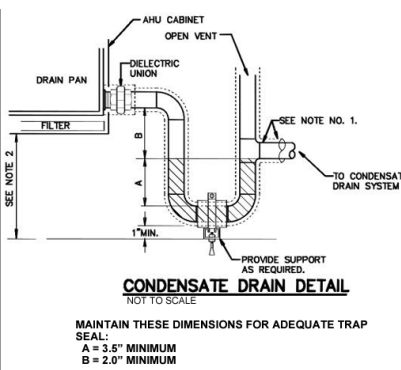

1-Way Cassette

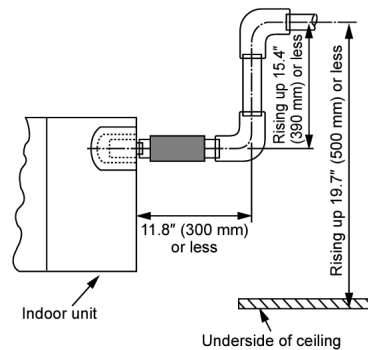

All drains have been insulated. Yes No
All drains have been checked for leaks. Yes No
All drains installed per instructions and local codes.

All drains are sloped properly. Yes No
All drains are supported properly. Yes No
Yes No



**Go Above.
Think Beyond.**

Carrier Toshiba VRF Installation Checklist

12.1 Indoor Unit – Condensate Safety Connection:

The following Indoor Units have a connection on the unit's main PCB.

NOTE: Some of these may not show in factory documentation.

MML1-U Floor Console Exposed } CN30
MMLB-U Floor Console Recessed }

MMD1-U Outside Air Duct } CN34
MMDV-U Vertical Duct }
MMC1-U Underceiling }
MMUM-U Compact Cassette }
MMU1-U Cassette }
MMUY-U 1-Way Cassette }
40QQ-U Rooftop }
MMDP-U Low Static Duct }
MMDB-U Med Static Duct }
MMDH-U High Static Duct }
MMD1-U Outside Air }
MMK1-U High Wall }

IDU PCB Example

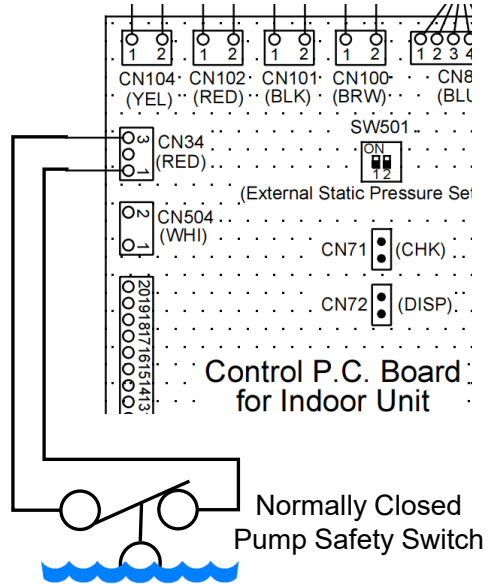

Attention:
Zero Volt Connection

12.2 Indoor Unit – Optional Condensate Safety Connection:

Optional Kit – TCB-KBCN61HAE

Available for all Carrier Toshiba Indoor Units

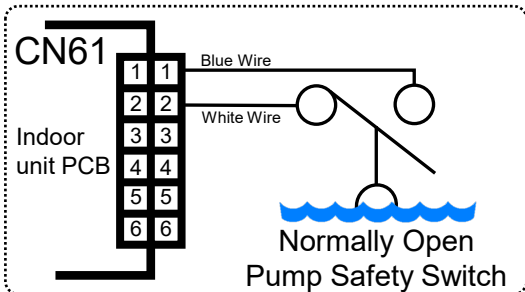

Change DN
Code Setting
2E to "0001"



Attention:
Zero Volt Connection

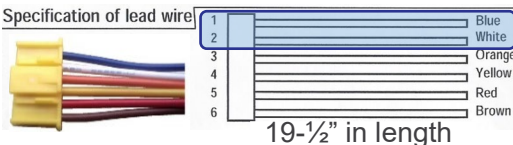

Pin No. & function	Specification																		
1	<table border="1"> <thead> <tr> <th>No.</th> <th>Function</th> <th>Action</th> </tr> </thead> <tbody> <tr> <td>Item code 2E</td> <td>ON/OFF Input External ON/OFF input</td> <td>ON OFF</td> </tr> <tr> <td>0000</td> <td>Connect</td> <td>Pulse input Pulse width 200 to 300ms Pulse interval 200ms or more</td> </tr> <tr> <td>(At shipment)</td> <td>Cut</td> <td>Static input ON OFF</td> </tr> <tr> <td>0001</td> <td>Connect</td> <td>Leaving ON prohibition reset OFF & Prohibition prevention control</td> </tr> <tr> <td>Cut</td> <td>No action</td> <td>Heating = Lowest set point Cool/Dry = Highest set point Auto/Fan = neglect</td> </tr> </tbody> </table> <p>(Item code setting ---Please refer indoor unit installation manual)</p>	No.	Function	Action	Item code 2E	ON/OFF Input External ON/OFF input	ON OFF	0000	Connect	Pulse input Pulse width 200 to 300ms Pulse interval 200ms or more	(At shipment)	Cut	Static input ON OFF	0001	Connect	Leaving ON prohibition reset OFF & Prohibition prevention control	Cut	No action	Heating = Lowest set point Cool/Dry = Highest set point Auto/Fan = neglect
No.	Function	Action																	
Item code 2E	ON/OFF Input External ON/OFF input	ON OFF																	
0000	Connect	Pulse input Pulse width 200 to 300ms Pulse interval 200ms or more																	
(At shipment)	Cut	Static input ON OFF																	
0001	Connect	Leaving ON prohibition reset OFF & Prohibition prevention control																	
Cut	No action	Heating = Lowest set point Cool/Dry = Highest set point Auto/Fan = neglect																	
2	0V (COM for 1,2 Pin)																		
3	ON/OFF prohibiting/permitting Input signal make permit/prohibit of individual remote controller ON/OFF (During prohibition, LCD is shown "Central controlling mark")																		
4	Operation output (Open collector) ON signal output during air conditioner operation (answerback to external)																		
5	DC 12V (COM for 4,5 Pin)																		
6	Alarm output (Open collector) ON signal output during alarm operation																		



**Go Above.
Think Beyond.**

Carrier Toshiba VRF Installation Checklist

13.1 Electric Wiring – Power Wiring Outdoor Unit:

Every outdoor unit must have a dedicated power supply.
Power supply wiring shall be installed in compliance with NEC and local codes.

Header Unit (A) circuit breaker size.		AMP
Follower Unit (B) circuit breaker size.		AMP
Follower Unit (C) circuit breaker size.		AMP
Header Unit (A) Wire Size.		AWG
Follower Unit (B) Wire Size.		AWG
Follower Unit (C) Wire Size.		AWG
Use crimp style ring connectors for all wiring connections.		
L1, L2, L3 wiring connected.	Yes	No
Ring crimp connectors used.	Yes	No
Ground wire connected.	Yes	No
Strain relief wire strap is tight.	Yes	No

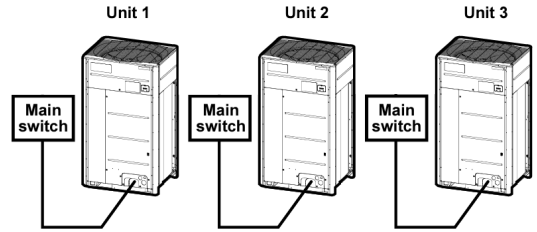

Correct



Not Acceptable

13.2 Electric Wiring – Power Wiring Indoor Unit(s):

The power supply for the indoor units must be separate from the outdoor unit

Enter circuit breaker size.	AMP			L1, L2 wiring connected.	Yes	No
Enter line voltage wire size.	AWG			Ground wire connected.	Yes	No
Strain relief wire clamp is tight.		Yes	No	All-indoor units on same circuit.	Yes	No

13.3 Electric Wiring – Control Wiring:

Reference the V-Pro Report's for Control Wiring layout drawing.

All Control wiring is stranded, 2-conductor, non-polarity, shielded wire 16 AWG.	Yes	No
If not, enter what was used here.		
Wiring shield is connected to the "S" screw.	Yes	No
U1 & U2 control wiring is connected from the Header outdoor unit and daisy chained to each indoor unit, stopping at the last indoor unit on the refrigerant circuit.	Yes	No
Twinned or Triple Outdoor Unit Combinations has control wiring connected from the outdoor Header unit (A) U5 & U6 to the outdoor Follower unit(s) (B) & (C).	Yes	No
All shields are connected to the "S" screw.	Yes	No

Summary of communication wiring

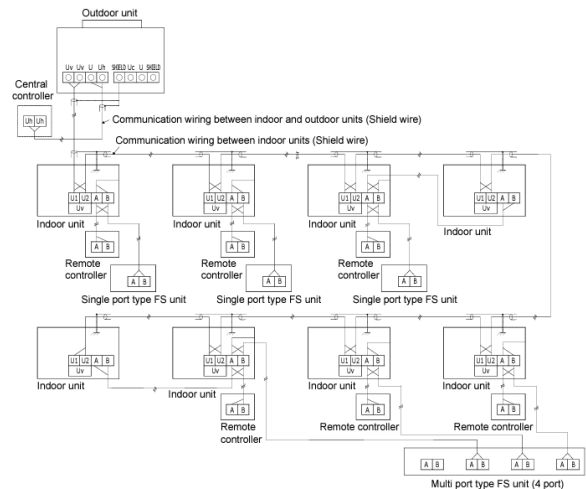



**Go Above.
Think Beyond.**

Carrier Toshiba VRF Installation Checklist

13.4 Electric Wiring – Control Wiring Wired Remote Controller:

Reference the V-Pro Report's for Control Wiring layout drawing.

Remote Controller wiring is stranded, 2-conductor, non-polarity, 16 AWG wire. Yes No

If the remote controller wire is different then above, enter type of wire used.

Remote controller is connected to A & B on corresponding indoor unit. Yes No

For group control of indoor units, A & B wiring is connected to the header indoor unit of the group and daisy chained to the follower unit's A & B terminals.

Are there any group controlled. Yes No

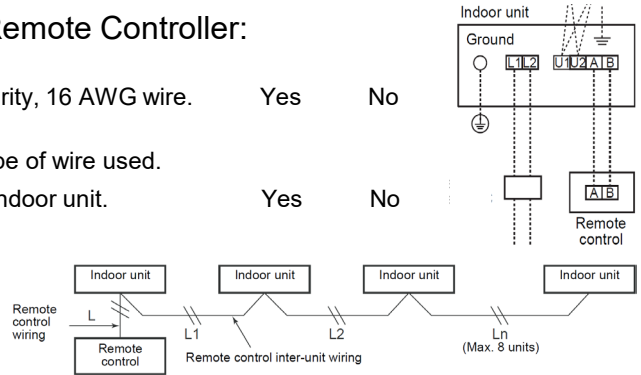

13.5 Electric Wiring – Control Wiring Outdoor Unit:

Indoor Unit daisy chain connected to U1, U2. Yes No

Control wire shield connected to "Shield screw". Yes No

Follower Units B & C daisy chained to U5, U6. Yes No

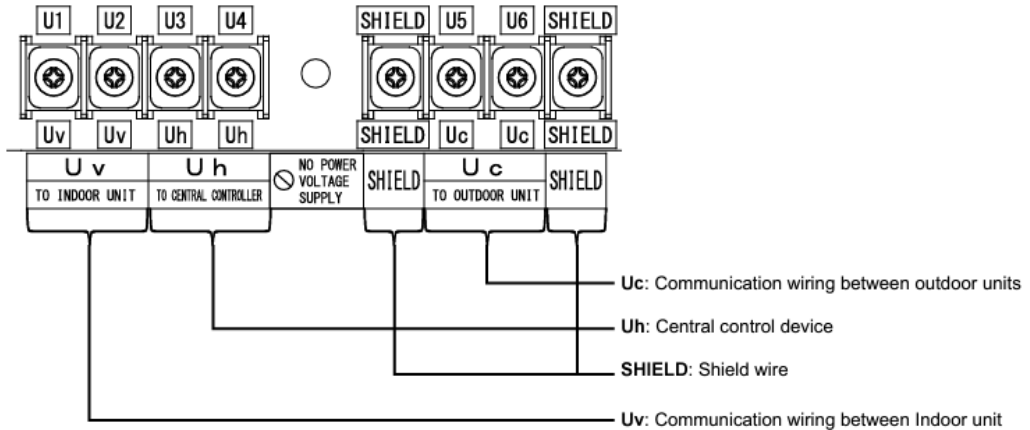



**Go Above.
Think Beyond.**

Carrier Toshiba VRF Installation Checklist

14. Final Installation Checks:

All indoor units, flow selectors and outdoor units are installed per the installation instructions.	Yes	No
All condensate lines have been installed, insulated and supported per indoor unit installation instructions, local codes and state codes.	Yes	No
All refrigerant piping has been installed, insulated and supported per indoor unit, flow selector & outdoor unit installation instructions, local and state codes.	Yes	No
All control and power wiring has been installed and secured per indoor & outdoor unit installation instructions, local codes and national codes.	Yes	No
All wired controllers have been installed per the installation instructions.	Yes	No
All shipping supports (blue tape) have been removed from the indoor blower wheels.	Yes	No
All equipment covers and panels have been re-installed.	Yes	No
After the additional refrigerant charge has been added and all of the outdoor unit service valves have been fully opened, power should be applied to the outdoor unit only - for a minimum of 12 hours. If this is not done start up will not be able to be performed.	Yes	No

Do NOT apply power to the indoor units at this time.
Verify SW01, SW02 & SW03 are all in position 1.
Once power is applied the control should display: U.-.E19.

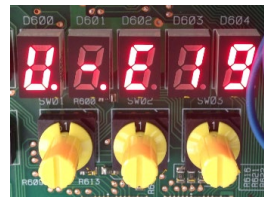

15. Evacuation Mode – Pulse Motor Valve (PMV) Forced Open Mode:

More detailed information can be found in the Service Manual.

This function is provided to open or close forcedly PMV for 2 minutes in all the indoor units by the switch operation on the interface P.C. board of the outdoor unit. This function is also used to open PMV fully when turning off the power and executing an operation.

<Operation>

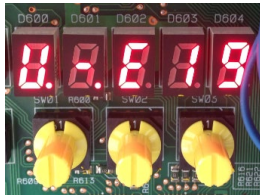

[Open fully] Set the switches SW01 / SW02 / SW03 on the interface P.C. board of the outdoor unit to [2/3/1] and press SW04 for 2 seconds or more.(Display appears on 7-segment display for 30 seconds as follows.) [P.] [FF]

[Clear] After 30 seconds (1 minutes for “Close fully”) after setting up, the opening automatically returns to the normal opening.



**Go Above.
Think Beyond.**

Carrier Toshiba VRF Installation Checklist

16. Start Up Assistance Request:

For start-up assistance - coordinate with CE Technical Support a minimum of 2 weeks prior to the expected start-up date. Send us this fully completed form for each system requiring an assisted commissioning. If you have a Centralized Control such as a Touch Screen, BACnet or LonWorks, please fill out a Controls Installation Checklist as well.

1st Choice Scheduled Date:

2nd Choice Scheduled Date:

Once received our VRF Specialist will call to review these forms, once reviewed CE will confirm a date for commissioning.

Forms must be completed by Installing Contractor:

Today's Date:

Company Name:

Technician / Installer:

Signature:

By signing this the contractor confirms all information provided is correct. If CE arrives on site and system is not ready for commissioning additional fees may be charged.